

Mobrey

Boiler water level controls

- Fully in accordance with the requirements of P.M.5, TRD604. pr EN12953-9 and 12952-11 and SAFed PSG2.

Introduction

Mobrey originally entered the industrial boiler control market in 1923 with a range of steam operated equipment. Since that time the range has expanded to cover most aspects of control associated with the boiler house. Products range from electro-mechanical level devices to sophisticated electronic energy saving products that form a major step towards the fully automated boilerhouse. These reliable products are described in greater detail on the following pages and each carries the quality and service guarantee synonymous with the Mobrey name.

Alarm and Pump Control

Mobrey Vertical Air Break Controls are a comprehensive range of magnetically operated water level controls. They are designed to meet all the requirements for automatic on/off control of boiler feed pump, burner cut-out, high and/or low level alarm or any combination of these. They comply fully with the recommendation of The British Health and Safety Executive Guidance Note P.M.5, and SAFed PSG2.

Float operated controls also comply with European standards TRD604. pr EN12953-9 and 12952-11 when used in conjunction with the ACCS unit described in BP203.



Sequencing blowdown valves

The Mobrey Sequencing Valve is designed to function as a manually operated combined water isolating valve and sequencing valve. It provides positive purging of the water connection, float chamber and steam connection of a boiler control as required by P.M.5, TRD604. pr EN12953-9 and 12952-11 and SAFed PSG2.

Fail Safety, High Integrity, Self Monitoring

Float operated level controls are inherently **Fail-Safe** and comply fully with the definitions for this parameter as stated by UK and European Standards. Float controls can be made to comply with the definitions of **High Integrity** and **Self Monitoring** by the addition of automatic checking equipment as described in Mobrey leaflet BP203. The equipment is unique because it actually carries out a dynamic test on the level equipment, which is a more searching requirement than an electrical integrity test. Again this equipment fully complies with the requirements of PM5, TRD604, SAFed PSG2 the harmonised European Standards pr EN12953-9 and 12592-11.

Conversion Heads

These VABC heads are designed to fit into existing float chambers, and provide an economical method of updating boiler water level controls to the latest models. Conversion heads are available for on/off controls and modulators.

Modulating water level controllers

The Mobrey Controller is a single element electro-hydraulic control with an electronic feedback. The system comprises a control unit float chamber, a feedline modulating valve and a control box. It is used for the throttle control with the modulating valve in the feedline.

Vertical air break alarm and pump controls

Description

The Mobrey Vertical Air Break Controls (VABC) are a comprehensive range of magnetically operated water level controls for steam boilers. They are designed to meet all requirements for automatic on/off control of boiler feed pump, burner cut out, high and/or low level alarm or any combination of these complying fully with the recommendations of the British Health and Safety Executive, PM5 and SAFed PSG2 as well as European Standards TRD604, and pr EN12952-11 and 1253-9 when used in conjunction with the ACCS unit. See BP203. Refer to Fig. 6 for typical installations. Models available with Industrial (NEMA4), or Marine Heads. TUV approved models are available in Chambers and for Direct Mounting application.



Operation

The Mobrey VABC is of glandless construction. A primary permanent magnet attached to the float rod slides vertically inside a non-magnetic stainless steel tube and transmits the movements of the float to a secondary magnet in each switch unit. There are two pairs of contacts which are operated with a snap action and held by repulsion between the secondary magnet and the tertiary magnet of the switch unit assembly.

Operating Levels

Differentials

Each switch has a nominal fixed water level differential of 25mm between circuits A-A and B-B. To obtain a differential greater than 25mm, two switch units must be used.

The minimum water level differential for two switch units is 33mm, with switch centres positioned 8mm apart.

The maximum adjustable differential for two switch machines will vary with the operating range of each model, i.e. the distance between rising and falling level which is required to operate the switches positioned at the extreme ends of their adjustments - Fig. 2.

Switch adjustment - Fig. 1 and 2. Switches have adjustments as follows:

Range	Adjustment	Fixed differential		
62mm	37mm	+ 25mm	=	62mm
150mm	125mm	+ 25mm	=	150mm
250mm	225mm	+ 25mm	=	250mm

Electrical Characteristics

Single-pole double-throw operation for :

AC

Maximum voltage	440V
Maximum Current	5A
Minimum Power Factor	0.4
Maximum Power	2000VA

DC

Resistive

Maximum Power	100W
Maximum Voltage	250V
Maximum Current	5A

Inductive

Maximum Voltage	250V
*Maximum Current	0.5A
Maximum Time Constant	40 ms
Maximum Power	100W

*Maximum up to 2A dependent upon time constant of circuit, consult factory

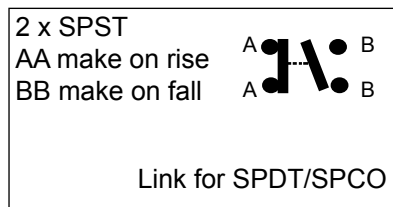

Switches must not be used for the direct starting of motors. Contacts should be wired in series with the operating coils of relays, contact starters or solenoid valves, and fused separately.

Two 25mm BS.4568 cable entries are provided for the electrical connections. A sufficient length of flexible cable must be fitted to permit easy removal of the switch head and float assembly for routine maintenance.

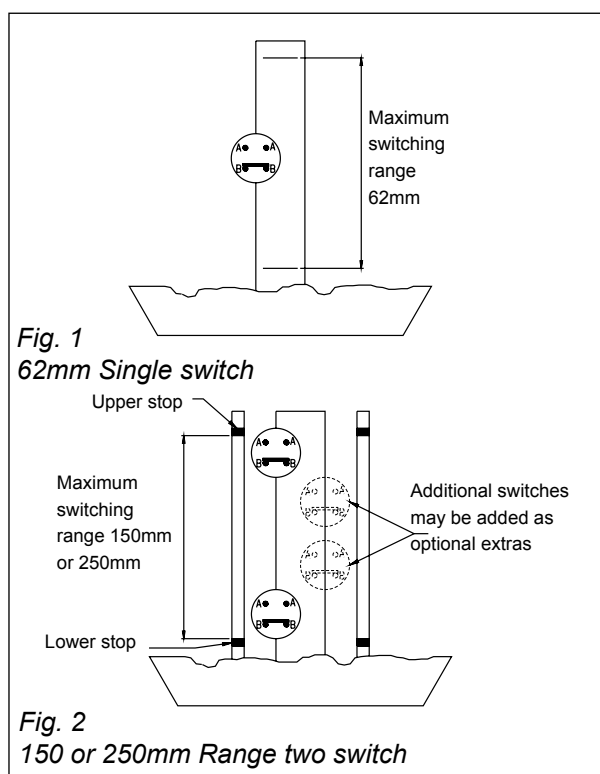

Dimensions and ordering information : Chamber mounted models

Type Number	Operating Range	No. of Switches		Flanged & Screwed Connections	Dimensions						
		Std.	Max		C	G	H	H ₁	L	W	F
Cast iron chamber - working pressure: 13kg/cm²											
BX02/1	62	1	-	BS4504.25-16/11	-	102	193	303	366	182	160
BX05/2	150	2	4	BS4504.25-16/11	-	102	293	497	468	277	160
BX07/2	250	2	6	BS4504.25-16/11	-	102	393	602	557	370	160
Fabricated steel chamber - working pressure: 21kg/cm²											
BX09/1	62	1	-	BS4504.25-40/2	-	87	193	303	366	182	160
BX10/2	150	2	4	BS4504.25-40/2	-	87	293	497	468	277	160
BX11/2	250	2	6	BS4504.25-40/2	-	87	393	602	557	370	160
Fabricated steel chamber - working pressure: 32kg/cm²											
BX12/1	62	1	-	BS4504.25-40/2	-	102	193	303	559	372	160
BX13/2	150	2	4	BS4504.25-40/2	-	100	293	497	559	372	160
BX14/2	250	2	6	BS4504.25-40/2	-	100	393	602	559	372	160

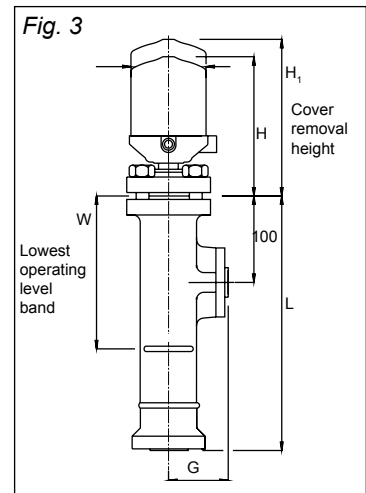

Type Number	Operating Range	No. of Switches		Flanged Connections	Screwed Bottom Conn. BSP	Dimensions						
		Std.	Max			C	G	H	H ₁	L	W	F
Cast iron chamber - working pressure: 13kg/cm²												
BX03/1	62	1	-	25-16/11	1"	216	102	193	303	448	277	160
BX15/1	62	1	-	20-16/11	1"	180	100	193	303	480	240	160
BX87/1	62	1	-	20-16/11	1"	180	135	193	303	480	240	160
BX16/2	120	2	4	20-16/11	1"	180	100	293	497	480	240	160
BX88/2	120	2	4	20-16/11	1"	180	135	293	497	480	240	160
BX06/2	150	2	4	25-16/11	1"	216	102	293	497	448	277	160
BX08/2	250	2	6	25-16/11	1"	317	102	393	597	557	370	160
Fabricated steel chamber - working pressure: 21kg/cm²												
BX17/1	62	1	-	20-40/2	½"	270	100	193	303	570	335	160
BX45/1	62	1	-	25-40/2	½"	270	100	193	303	570	335	160
BX18/2	120	2	4	20-40/2	½"	270	100	293	497	570	335	160
BX19/2	150	2	4	20-40/2	½"	270	100	293	497	570	335	160
BX20/2	150	2	4	25-40/2	½"	270	100	393	497	570	335	160
BX21/2	215	2	6	20-40/2	½"	270	100	393	602	570	335	160
BX22/2	215	2	6	25-40/2	½"	270	100	393	602	570	335	160
Fabricated steel chamber - working pressure: 32kg/cm²												
BX23/1	62	1	-	25-40/2	½"	350	112	193	303	595	372	160
BX24/2	150	2	4	25-40/2	½"	350	112	293	497	595	372	160
BX25/2	250	2	6	25-40/2	½"	350	112	393	597	595	372	160

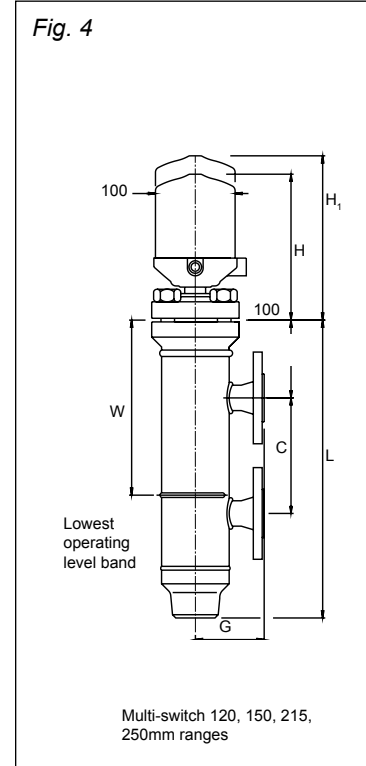

Explanation of type numbers

The type numbers are arbitrary except that BX denotes chamber mounting and BD direct mounting.
 The stroke number indicates the number of switch units fitted as standard. When extra switches are required this stroke number will indicate the total number of switches to be provided.
 When Marine models are required the letter 'M' should be inserted after the letters BX and before the number, e.g., the Industrial and NEMA 4 Model BX05/2 becomes BXM05/2 when in Marine construction.

Marine type approvals:

American Bureau of Shipping
 Bureau Veritas
 Germanischer Lloyd
 Lloyds Register of Shipping
 Det Norske Veritas
 Russian Maritime Register of Shipping
 TUV approved models (side and side connections only) are available on request. Before ordering please refer to Mobrey Measurement.

If the models shown here do not meet your specific requirements, please contact Mobrey Measurement for assistance.

Chamber Mounted Controls

Float Chambers - manufactured in approved materials :-

Cast iron equal to BS. 1452 Grade 17 for up to 13kg/cm² rating. Fabricated steel BS.3602 - HFS 27 for both 21kg/cm² and 32kg/cm² ratings. For chamber dimensions and process connections arrangement see dimension chart figures 3 and 4.

Switch head - containing one or more switch units mounted in a housing comprising a die-cast base with a zinc coated mild steel casing. Two 25mm BS.4568 cable entries are provided.
Switch units - have single pole double throw contacts, are latching and are positioned and held in place by clamp screws.

Centre tube - made of non-magnetic stainless steel and expanded into the top cover flange, it is fitted with a stop cap which also acts as a guide for the float rod carrying the primary magnet.

Float - manufactured in monel metal.

Float rod - manufactured in stainless steel.

For details on self testing/monitoring of chamber mounted controls refer to leaflet BP203.

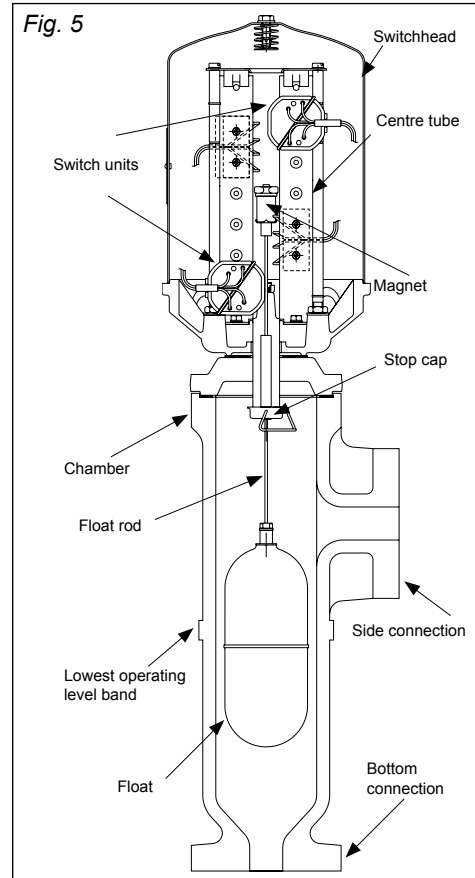
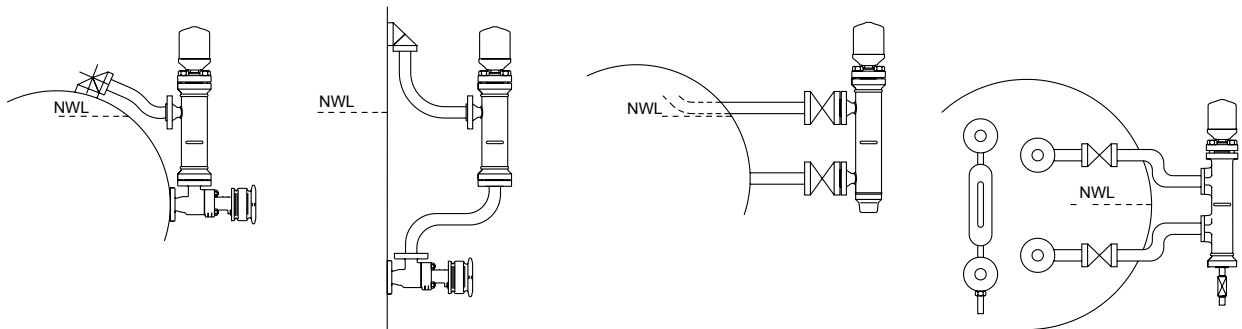

Fig. 6

Typical mounting arrangements

Arrangements of Mobrey Vertical Air Break Controls on various types of boiler



Side and bottom entry chamber with sequencing valve on horizontal boiler

Side and bottom entry chamber with sequencing valve on vertical boiler

Side and side entry chamber on horizontal boiler

Side and side entry chamber on steam drum of water tube boiler

The Chamber band mark indicates the lowest adjustment position of low level alarm and it is our recommendation that the positioning of the boiler control chambers relative to the water level gauge glasses and the N.W.L. is such that there is always water visible in the gauge glass even at the lowest operating band level.

Conversion Heads

Description

These Mobrey Vertical Air Break control heads are specifically designed to provide an economic method of updating old Mobrey mercury switch controls to the latest models. These 'Conversion Heads' will fit into existing chambers, and provide on/off pump control and alarm function.

Conversion Heads are also available for updating old Mobrey Teleflex Modulators.

A suitably adapted version of the Modulating Control head and float unit is provided for fitting into the existing float chamber. It will be necessary to replace the feed line valve with its modern counterpart and to provide the modern electronic control box.

Note

In all cases the type number of the existing equipment must be given when ordering.

This is to enable us to check the model number and the float rod length to be provided.

For the modulating control the basic information for sizing the valve lid and seat will be required.

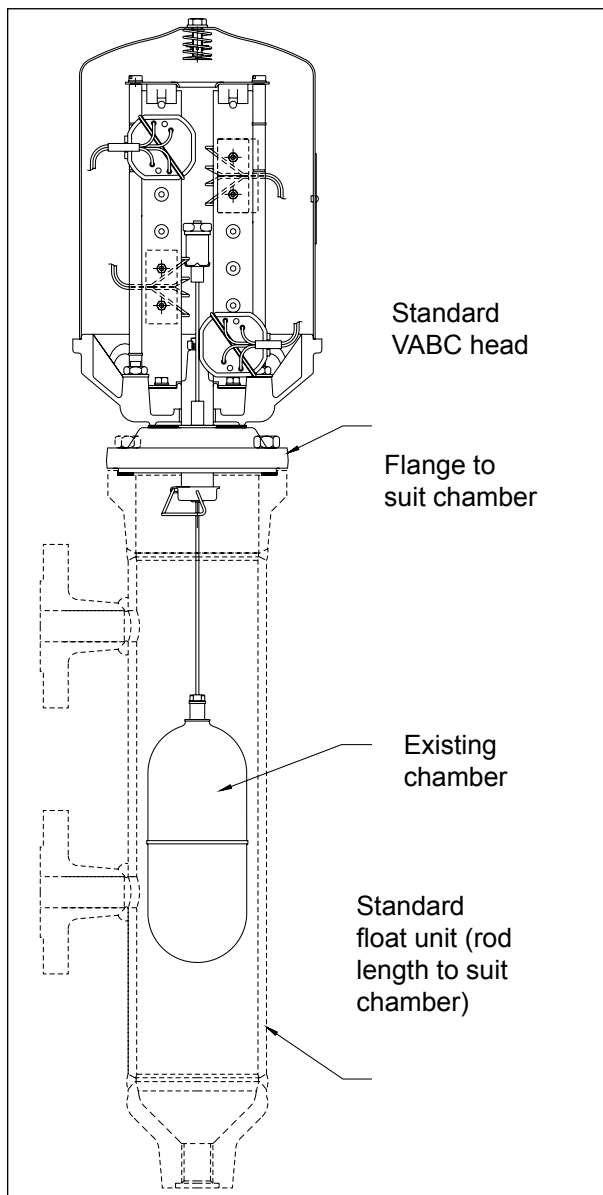

Features

- Save
 - Time
 - Money
 - Inconvenience
- Conforms fully to PM5 requirements.
- Uses existing wiring and chambers

If you cannot see the model number of your existing control listed here, or are unsure of which new model to order, please do not hesitate to contact Mobrey Measurement for further information.

Ordering Information

Type Numbers

Old unit numbers	Replacement unit
High and low alarms 100-MS6/F263 102-MS6/F263 129-MS70/F299 129-MS71/F300 133-MS70/F299 133-MS71/F300 125-MS71/F301	C250/2 C250/2 F250/2 F250/2 F250/2 F250/2 F250/2
Pump control and 1st low alarms 220-MS12/F284 220-MS16/F284 24-MS12/F216 24-MS16/F216 65-MS26/F22 64-MS26/F280 125-MS72/F295 125-MS76/F295	C150/2 C150/2 C150/2 C150/2 C150/2 C150/2 C150/2 C150/2
Single alarms 2nd low 125-MS73/F296 214-S90/F50 14-S90/F50 215-S90/F50 15-S90/F50 17-S101/F50 18-S90/F50	
Modulating controls 30310 30295	

Direct mounted water level controllers

Direct mounted models

Standard models

Direct Mounted Vertical Air Break Controls employ the same principles of operation and piece parts as the chamber mounted equivalents except that the chamber is exchanged for a large round flange and the tube assembly for mounting the control directly on to the boiler shell connection. A stilling or guide tube should be provided, which may be fixed or removable, to ensure that the float rod is not damaged and the correct vertical movement is achieved.

Direct mounted controls incorporating test facilities

These controls have the provision for testing the operation of the mechanism without lowering the level of water in the boiler. Testing can be initiated manually or by a timer. U.K. Patent 1279504 or 1473939 and foreign equivalents.

Hydraulic cup test facility

The test is achieved by lowering the float to the low water alarm level, by the following means :

The float rod includes a cup, above the float, which is fed with water from the boiler feed pump via small bore pipework and valves through the control mounting flange (see fig. 7) for approximately 24 seconds. The additional weight overcomes the buoyancy of the float, causing it to sink, stop the burner firing and operate the alarm system. After closing the test valve in the supply from the feed pump to the control, a small hole in the bottom of the cup drains off the water, permitting the float to rise to the normal operating position. Control of the water supply to the cup can alternatively be by means of a solenoid valve, which can

be initiated by a timer or a manually operated push button.

In this design the alarm switch remains fully adjustable.

Electromagnetic test facility

The switch head includes an inductive coil below the single switch subassembly (Fig. 8). This surrounds an armature located inside the stainless steel centre tube and fixed to the float rod.

To initiate the test cycle, the coil can be energised by a timer or a manually operated push button and the float will be thrust downwards to stop the burner firing and operate the alarm system.

When the coil is de-energised the float rises to its normal level. In this design the alarm switch unit is not adjustable.

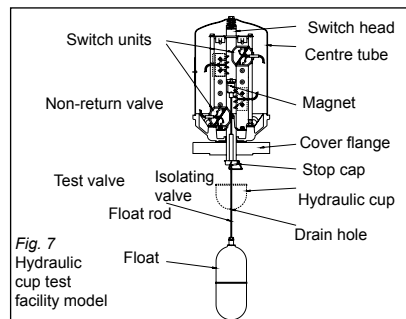

Fig. 7
Hydraulic
cup test
facility model

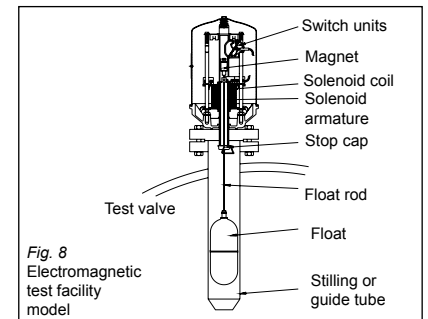
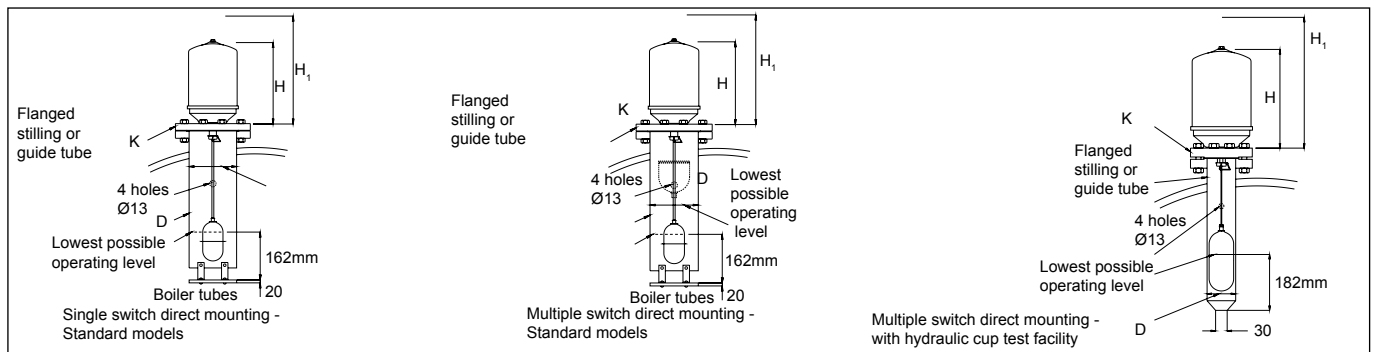

Fig. 8
Electromagnetic
test facility
model

Dimensions and Ordering Information : Direct Mounted Models



Type number Standard	Working press. at saturated steam kg/cm ²	Operating range	No of switches std. max.	Connection K BS4504	Float dim length dia	Dimensions			Max. float rod length
						D Min	H	H ₁	
BD01/1	21.0	62	1 1	100-40/2	152 x 67	77	193	303	765
BD02/2		150	2 4				293	497	
BD03/2		250	2 6				393	597	
BD04/1	32.0	62	1 1	100-40/2	155 x 90	100	193	303	1016
BD05/2		150	2 4				293	497	
BD06/2		250	2 6				393	597	
Pressures up to 32kg/cm ² available on request									
Hydraulic cup test facility	32.0	62 150 250	1 1 2 4 2 6	100-40/2	155 x 90	100	193	303	1016
BDT01/1									
BDT02/2									
Electromagnetic test facility	21.0	-	1 - 1 -	BM128mm sq 100-40/2	155 x 90	100	293	497	1016
BDT04/1									
BDT05/1									

For information on Self monitoring / Self testing Mobrey controls, please refer to leaflet BP203.

Modulating water level controllers

Description

The Mobrey Modulating Controller is a single element electro-hydraulic control with an electronic feedback system comprising:

- i) A control unit float chamber, mounted on the boiler shell, fitted with an Inductance Coil 'A' head assembly which can be made suitable for either Industrial or Marine Applications.
- ii) A flanged modulating valve, fitted with an Inductance Coil 'B' and twin solenoid valve assembly, which is mounted in the boiler feed water line.
- iii) An electronic control box.

Operation

A positive change of water level in the boiler alters the inductance value of Coil "A" causing an imbalance in the system. This signal is transmitted through the electronic control box to the appropriate solenoid valve on the modulating valve thus producing a change of hydraulic pressure on the piston assembly, the movement of which modulates the flow of water to the boiler.

Simultaneously this same vertical travel creates a change in the inductance value of Coil "B" until the balance is restored, thus closing the solenoid valve and hydraulically locking the modulating valve spindle. This sequence is repeated in very small steps until the feed water input equals the required evaporation rate of the boiler.

To prevent the modulating valve responding to random water movement against the general direction of level change, a 13mm reversal or (dead) band is incorporated in the electronic circuitry.

Low water alarm and burner cut out contacts are also provided within the control box to operate when the water level falls to a predetermined position.

Installation Note:

For the further safety of boilers it is recommended that the Mobrey Control Unit is mounted on a Mobrey Sequencing Valve.

The water connection from the boiler to the float chamber should be as short as possible and the control head float chamber should be mounted close to the gauge glasses.

The chamber band mark indicates the lowest adjustment position of the low level alarm and it is our recommendation that the positioning of the boiler control chambers relative to the water level gauges glasses and the N.W.L. is such that there is always water visible in the gauge glass even at the lowest operating band level. If required our technical staff will advise on individual installations.

General Note

Models shown are for 21kg/cm² maximum working pressure. Details of modules for 32kg/cm² will be provided on request.

Important Notice

Electronic control box must not be subjected to either vibration or excessive temperature. It is therefore recommended that they are NOT mounted directly on to the boiler shell.

Features

- Inherently stable
- Easily adjusted for individual operating requirements
- Instant reversion to hand control in emergency.

Application Notes

Throttle Control –

- Modulating valve in feed line.
- Suitable for automatic cold start conditions.
- Used for all pumps capable of operating against a closed discharge.

With a rising water level in the boiler, the modulating valve closes progressively to reduce the rate of feed into the boiler. The size of valve lid is determined by the *actual* capacity of the boiler plus an allowance. See nomogram on page 9.

Power failure and high water shutdown – with a third solenoid valve

Where one pump is feeding more than one boiler it is imperative that a boiler cannot be overfilled. Therefore a third solenoid valve can be installed on the modulating valve which is operated by either a loss of power on the boiler control circuit or the high water alarm. In either case the valve will be closed and prevent further water entering the boiler. The third solenoid valve can be retrofitted to existing valves.

Common feed pump arrangement

Multi-boiler installations operating on a common feed system require special sizing consideration and full details should be provided so that a suitable valve can be recommended.

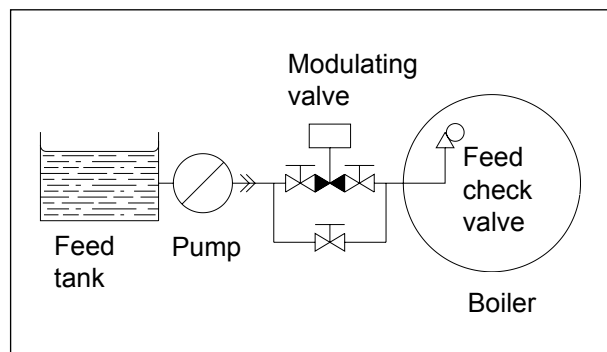

Control Units
Standard control heads and chambers

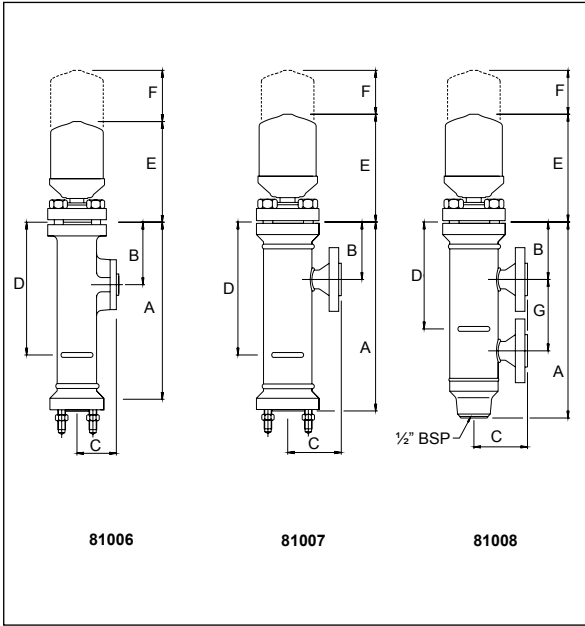

Type number	81006	81007	81008	81951
Material	Cast iron	Fabricated steel	Fabricated steel	Forged steel flange
Max. press. kg/cm ²	13	21	21	32
Connections	Side & bottom BS4504 25-16/11	Side & bottom BS4504 25-40/2	Side & side ND 25 NW 25	Direct mounted BS4504 100/40/2
A	468	468	570	-
B	100	100	100	-
C	102	87	100	-
D	277	277	335	-
E	390	390	390	390
F	430	430	430	430
G	-	-	270	-

Models are available for up to 32kg/cm² steam working. Details on request

Control Box

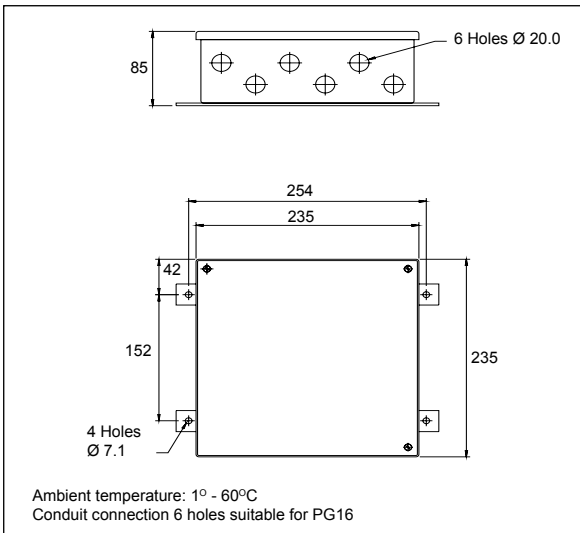

Electrical characteristics

Type number	80436	80660
Input supply	240V ac 50/60Hz ± 10%	110V ac 50/60Hz ± 10%

Input circuit protected by 1 amp HRC fuse.

Alarm and control relays protected by 2 amp HRC fuses.

Relay contacts voltage free rating:-

Max. voltage 250V ac Max. current 2 amp

Facility available to special order for separate supply to solenoid valves with 2 amp HRC maximum protection.

Output option: 0-10V available on request.

IMPORTANT NOTICE

Electronic control box must not be subjected to either vibration or excessive temperature. It is therefore recommended that they are not mounted directly on to the boiler shell.

Modulating Valves

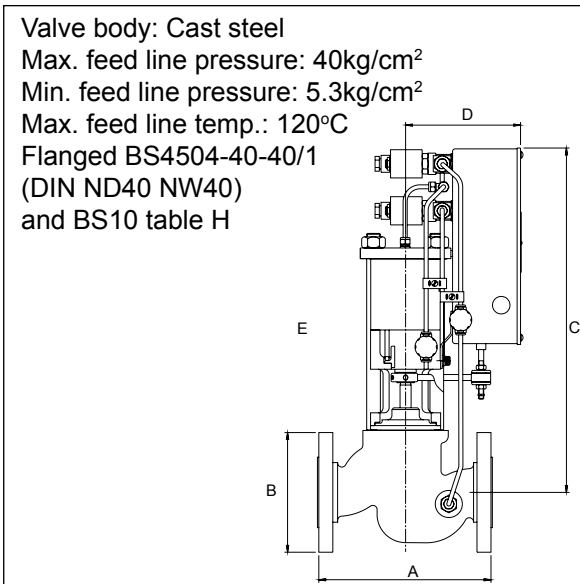

Type number	Flanged	No. of solenoid valves	Electrical supply
80310/*	Table H	2	230V ac 50Hz
80311/*	ND40	2	230V ac 50Hz
80653/*	NW40	2	110V ac 50Hz
80486/*	NW40	2	230V ac 60Hz
80310/80435/*	Table H	3	230V ac 50Hz
80311/80435/*	ND40	3	230V ac 50Hz
80653/80435/*	NW40	3	110V ac 50Hz

* Stroke letter to indicate valve lid size required:

A	200	B	150
C	406	D	140
E	425		

Note The internal trim on the Modulating valve can be changed without the need to replace the valve should operating conditions change.

Sizing of Valve Lids

A range of valve lids and associated seats are available and provide linear flow characteristics. a table of cv values for water (S.G.=1) is given below for valve lids in the fully open position.

Type of Lid	Cv = kg/hr for 1 kg/cm ²
A	1,690
B	2,260
C	3,030
D	4,100
E	5,480
F	7,480
G	9,840
H	13,520
I	18,480

Note: J Lid available on request for larger boilers.

Formulae for determining the Cv value and correct size of valve lid are given below. The pressure drop across the valve should be 1.4 kg/cm² or greater – normally, the higher the pressure drop the better the degree of control. The lid size is that with the nearest Cv value above the calculated value.

In the following example, an allowance of 0.4 kg/cm² has been made for all feed line losses. In practice, the allowance should be that of the installation under consideration and may well be in excess of 0.4 kg/cm², particularly where the feed pump is remote from the boiler and/or where an anti-syphon valve adjacent to the boiler feed check valve has been fitted.

$$CV = \frac{Q}{\sqrt{P}}$$

Where

Q = Actual Evaporation of Boiler plus 15 per cent margin kg/hr.

P = Pump Discharge Pressure kg/cm² when passing Q quantity of water minus (Boiler Maximum Working Pressure plus 0.4 kg/cm²).

Example:

Boiler evaporation (actual)
= 4,000 kg/hr.

Boiler Working Pressure
= 6.6 kg/cm²

Pump Discharge Pressure at
Q quantity
= 11 kg/cm²

$$Cv = \frac{4,000 + 15\%}{\sqrt{11 - (6.6 + 0.4)}} = 2.300$$

Lid required: Type C.

Mobrey Modulating Level Controller valve size chart

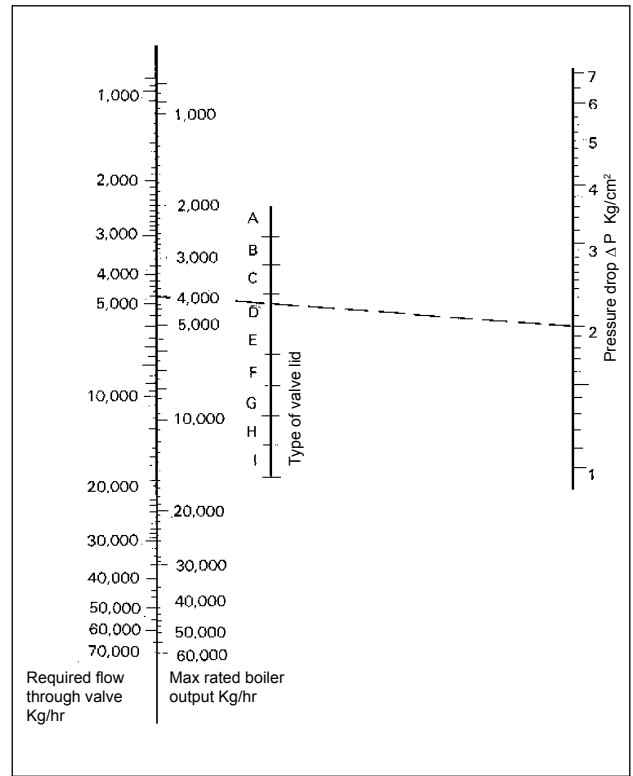

Note: Conversion heads to convert old Mobrey Teleflex modulators to the latest models are available.

Sequencing Blowdown Valves

Description

A purpose built flanged isolating angle and sequencing valve with 1/2" BSP screwed drain connection and back seating features, all valve trims are in stainless steel. It fully complies with the recommendations of Health and Safety Executive guidance note PM5 - for automatically controlled steam and hot water boilers.

Function

The Mobrey sequencing valve is designed to function as a combined water isolating valve and a sequencing valve to provide positive purging of the water connection, float chamber and steam connection of a boiler control.

Blowdown of float chamber and connections is effected separately and in a pre-determined sequence by the operation of the single specially designed handwheel.

Features

- One valve to provide separate blowdown of:
 - Control Chamber
 - Steam Connection
 - Water Connection
- Blowdown by predetermined sequence
- Stainless steel trim
- Back seating ensures packings are not subjected to continuous pressure
- Available with Imperial or Metric flanges
- Available for pressures up to 32 kgs/cm²



Sequence of operation

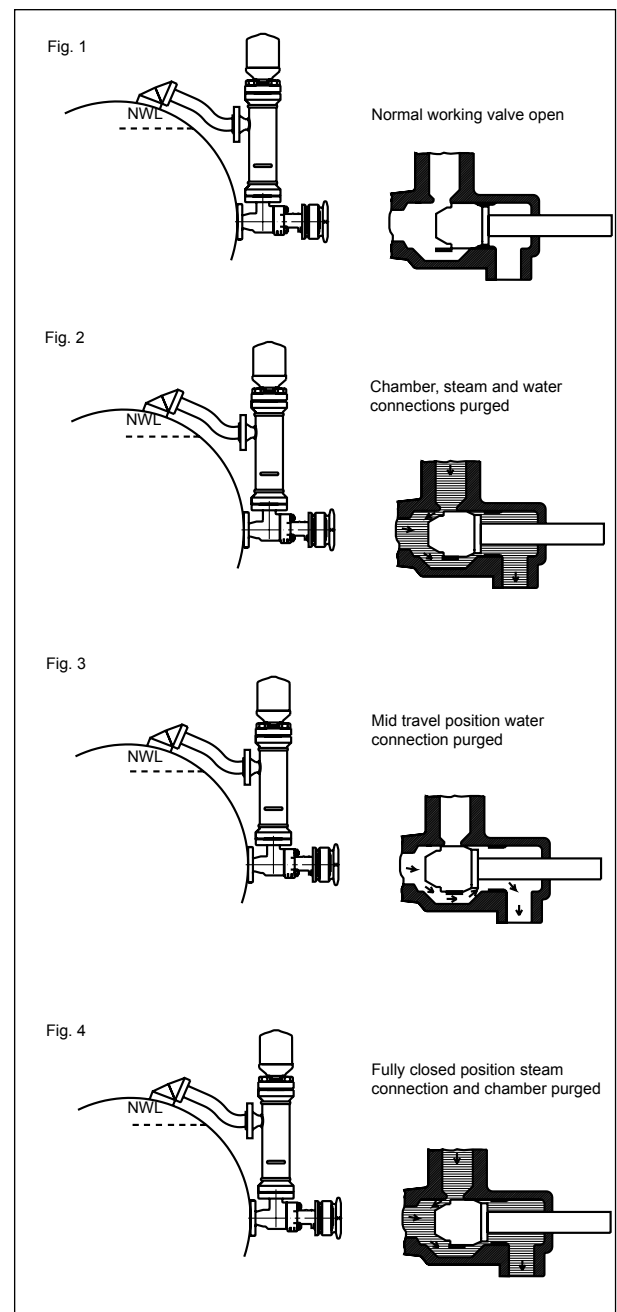

Dimensions and Ordering Information

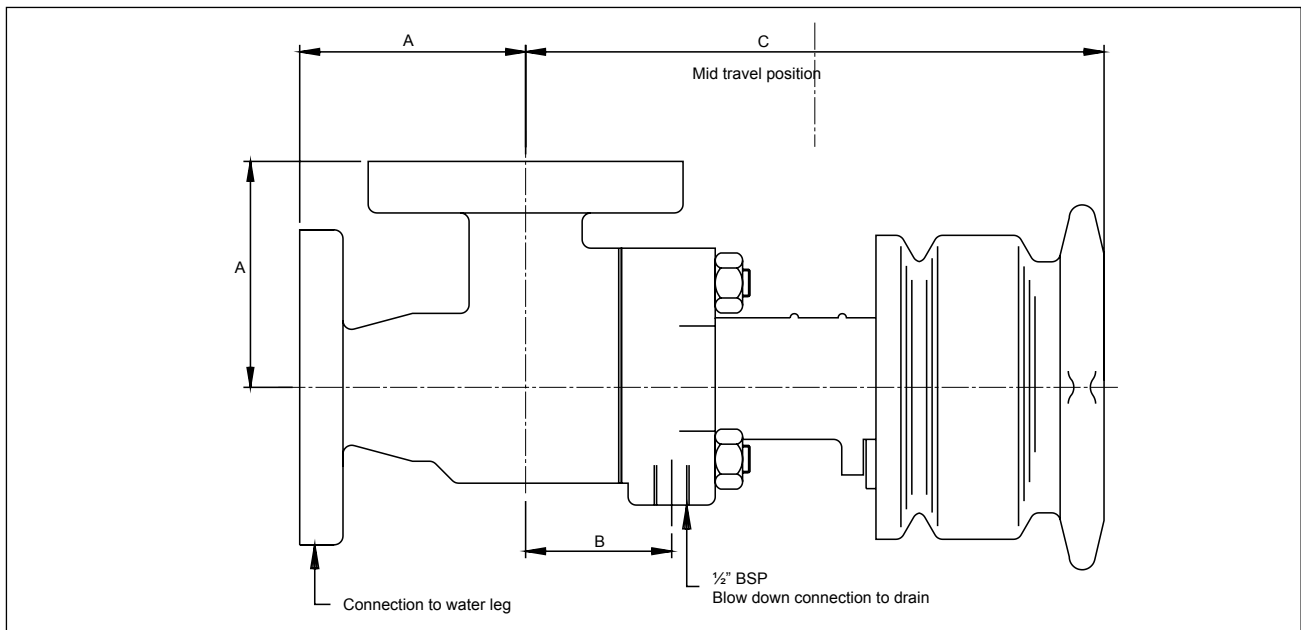

Models available

Type Number	Flange Connections BS4504	Material Body and Stuffing Box	Maximum Working Pressure Bar	Dimensions		
				A	B	C
80938	25-16/11	Cast Iron	13*	83	54	219
80947	25-25/21	Gunmetal	21	83	54	219
80951	25-40/1	Cast Steel	32	83	54	219
81390	BS10 Table H	Gunmetal	21	83	54	210

*For Lloyds applications maximum W.P. is 10.5 Bar

Important

The blowdown connection should be piped directly to an independent covered drain, or tundish with removable lid, capable of accepting the full discharge without danger of blow-back. The bore of blowdown pipe should not be less than 12mm and the length should be kept as short as possible. Sight glasses must not be fitted in the blowdown line.

Blowdown Procedure Card:

Mobrey produce a useful blowdown procedure card, part number BP109, which is available on request.

Steam

Associated Boiler Products

Electronic Probes

Mobrey Measurement manufactures a full range of conductive and capacitive probe controls for application on steam boilers. This equipment fully complies with the latest boiler specifications.

Automatic Control Check System (ACCS)

This product has been designed to provide high integrity and self-monitoring to float operated controls in compliance with the latest boiler standards

Steam and water Flow

Flow meters are available for steam, water and fuel flow measurement using orifice and low energy loss averaging pitot tube technology. Non intrusive meters are available for liquid flow.

General Level

Mobrey Measurement is a level, flow, pressure, density and viscosity measurement instrument company. If you have a problem we will have the solution

Smoke Density

Self-calibrating, Obscuration Meters available on request

TDS Control, Timed Bottom Blowdown, Remote Alarm & Shut down panels

For UK and Eire markets only – Full customer service provision

Mobrey Measurement is able to provide a full design, installation, commissioning and maintenance service for site installed instrumentation through it's Service Division. This organisation is able to provide a full boiler house installation and maintenance service and provide turnkey installation solutions covering all control and instrumentation functions. The following gives a typical list of operations carried out by engineers and technicians directly employed by the company and operating through 5 regional offices throughout the UK

- Total compliance with unmanned boiler regulations, Health and Safety guidance note PM5, SAFed PSG2, and prEN12953-9 and prEN12952-11 for both existing Mobrey float controls and electronic probe installation
- Steam and water flow monitoring, heat and mass flow calculation using Mobrey's unique range of products.
- Tank and level monitoring solutions using Mobrey's unique range of products.
- Complete automation solutions bringing together major manufacturers equipment into a single turnkey solution **Mobrey Measurement Service Division** is an engineering company providing engineering solutions.



Insurance inspection



High integrity, self-monitoring float controls



Electronic probe installation



Flowmetering

Head Office
Tel: 01753 756634
756622
756623
Fax: 01753 579523

Scotland, N Ireland & Eire
Tel : 0141 613 1441
Fax: 0141 613 2093

Northern Installation
Tel : 0161 209 4450
Fax: 0161 480 6297

Southern Installation
Tel : 01474 355976
Fax: 01474 564349

International

Emerson Process Management Mobrey Measurement

158 Edinburgh Avenue, Slough,
Berks UK SL1 4UE
T +44 (0) 1753 756600
F +44 (0) 1753 823589
www.mobrey.com